



**AWMS METHANE RECOVERY PROJECT CL06-S-01,
REGIÓN DEL LIBERTADOR
GENERAL BERNARDO O'HIGGINS, CHILE**

UNFCCC Clean Development Mechanism
Simplified Project Design Document
for
Small Scale Project Activity



**DOCUMENT ID: CL06-S-01
VER 1, 20 SEP 06**



**CLEAN DEVELOPMENT MECHANISM
SIMPLIFIED PROJECT DESIGN DOCUMENT
FOR SMALL-SCALE PROJECT ACTIVITIES (SSC-CDM-PDD)
Version 02**

CONTENTS

- A. General description of the small-scale project activity
- B. Baseline methodology
- C. Duration of the project activity / Crediting period
- D. Monitoring methodology and plan
- E. Calculation of GHG emission reductions by sources
- F. Environmental impacts
- G. Stakeholders comments

Annexes

Annex 1: Information on participants in the project activity

Annex 2: Information regarding public funding

**Revision history of this document**

Version Number	Date	Description and reason of revision
01	21 January 2003	Initial adoption
02	8 July 2005	<ul style="list-style-type: none">• The Board agreed to revise the CDM SSC PDD to reflect guidance and clarifications provided by the Board since version 01 of this document.• As a consequence, the guidelines for completing CDM SSC PDD have been revised accordingly to version 2. The latest version can be found at http://cdm.unfccc.int/Reference/Documents.

**SECTION A. General description of the small-scale project activity****A.1. Title of the small-scale project activity:**

AWMS Methane Recovery Project CL06-S-01, Región del Libertador General Bernardo O'Higgins, Chile.

A.2. Description of the small-scale project activity:

Purpose: The purpose of this project is to mitigate and recover animal effluent related GHG by improving AWMS practices.

Worldwide, agricultural operations are becoming progressively more intensive to realize economies of production and scale. The pressure to become more efficient drives significant operational similarities between farms of a “type,” as inputs, outputs, practices, genetics, and technology have become similar around the world.

This is especially true in livestock operations (swine, dairy cows, etc.) which can create profound environmental consequences, such as greenhouse gas emissions, odour, and water/land contamination (including seepage, runoff, and over application), that result from storing (and disposing of) animal waste. Confined Animal Feeding Operations (CAFOs) use similar Animal Waste Management System (AWMS) options to store animal effluent. These systems emit both methane (CH₄) and nitrous oxide (N₂O) resulting from both aerobic and anaerobic decomposition processes.

This project proposes to apply the Methane Recovery methodology identified in Section III.D, of the Indicative Simplified Baseline and Monitoring Methodologies for Small-Scale CDM Project Activity Categories, to swine CAFOs located in Región del Libertador General Bernardo O'Higgins, Chile. The proposed project activities will mitigate and recover AWMS GHG emissions in an economically sustainable manner, and will result in other environmental benefits, such as improved water quality and reduced odour. In simple terms, the project proposes to move from a high-GHG AWMS practice, an open air lagoon, to a lower-GHG AWMS practice, a controlled temperature anaerobic digester with capture and combustion of resulting biogas.

Contribution to sustainable development:

In October 2001, Chile’s permanent representative to the United Nations, Ambassador Juan Gabriel Valdes, said the concept of sustainable development is comprised of three pillars:

1. protection of the environment,
2. economic growth, and
3. social development.

To these ends, the ambassador said the viability of sustainable development in South America requires a “stable, predictable, open and inclusive international economic system, in which the environment dimension is recognized as an opportunity for investments and trade and not as a barrier.”¹

¹ <http://www.un.int/chile/Statements/speech20011030>



Chile passed la Ley de Bases del Medio Ambiente (Law of Bases of Environment) in 1994 with the expressed intent to “recover and improve environmental quality; prevent environment deterioration; introduce environmental considerations in the productive sector; and involve citizens in environmental management.”²

The law also created the National Commission on the Environment (CONAMA), which was charged with the “mission to promote the environmental sustainability of the process of development and to coordinate the actions derived from the politics and definite strategies by the government in environmental matter.”³

Chile’s pork production has expanded tremendously during the last two decades, from 66 thousand metric tons of pork in 1985 to 372 thousand metric tons in 2004, an average yearly expansion of more than 20%. The latest statistics show that Chile possesses a total population of 2.3 million pigs up from 1.5 million in 1995.⁴ Considering that an average hog produces 5.8 kg of effluent a day, a potential 4.8 metric tons are being produced a year in Chile.

Table A1. Daily production of effluent by type of porcine⁵

Stage	Manure kg/day	Manure and Urine kg/day	Volume litres/day	Volume m ³ /animal/month
25-100 kg	2.3	4.9	7.0	.25
Gestating sows	3.6	11.0	16.0	.48
Nursing sows	6.4	18.0	27.0	.81
Boar pig	3.0	6.0	9.0	.28
Piglet	0.35	0.95	1.4	.05
Average	2.35	5.8	8.6	.27

The proper handling of this large quantity of CAFO animal waste is critical to protecting human health and the environment. Because of the practices employed by farmers, the design, location, and management of livestock operations are critical components in ensuring an adequate level of protection of human health and the environment.⁶

This project activity will also have positive effects on the local environment by improving air quality (i.e., reducing the emission of Volatile Organic Compounds (VOCs) and odour) and will set the stage for future on-farm projects (i.e., changes in land application practices) that will have an additional positive impact on GHG emissions with an attendant potential for reducing groundwater contamination problems.

This project activity will also increase local employment of skilled labour for the fabrication, installation, operation and maintenance of the specialized equipment. Finally, this voluntary project activity will

² <http://www.conama.cl/portal/1255/article-27873.html>

³ <http://www.conama.cl/portal/1255/propertyname-1647.html>

⁴ <http://www.thepigsite.com/FeaturedArticle/Default.asp?Display=1436>

⁵ Kruger I, Taylor G, Ferrier M (eds) (1995) ‘Australian pig housing series: effluent at work’ (NSW Agriculture: Tamworth). Another outstanding reference for manure output is: Lorimor, Powers, et.al “Manure Characteristics”, Manure Management Series, MWPS-18, Section 1; pg 12.

⁶ Speir, Jerry; Bowden, Marie-Ann; Ervin, David; McElfish, Jim; Espejo, Rosario Perez, “Comparative Standards for Intensive Livestock Operations in Canada, Mexico, and the U.S.,” Paper prepared for the Commission for Environmental Cooperation.



establish a model for world-class, scalable animal waste management practices, which can be duplicated on other CAFO livestock farms throughout Chile, dramatically reducing livestock related GHG and providing the potential for a new source of revenue and green power.

The proposed methane recovery project uniquely satisfies the Chilean government priorities for environmental stewardship and sustainability while positioning rural agricultural operations to develop and use renewable (“green”) power. Indeed, it does so with no negative consequences and with a series of environmental and infrastructure co-benefits.

Because the proposed project establishes an advanced AWMS the project participants believe the farm managers will adopt – and continue to practice – AWMS practice changes that result in meaningful, and permanent, GHG emission reductions beyond the project’s expected lifespan.

A.3. Project participants:

Name of Party involved (*) (host) indicates a host Party)	Private and/or public entity(ies) project participants (*) (as applicable)	Kindly indicate if the Party involved wishes to be considered as project participant (Yes/No)
Chile (host)	<ul style="list-style-type: none"> • AgCert International plc • AgCert Chile Servicios Ambientales Limitada 	No

A.4. Technical description of the small-scale project activity:

A.4.1. Location of the small-scale project activity:

A.4.1.1. Host Party(ies):

The host party for this project activity is **Chile**.

A.4.1.2. Region/State/Province etc.:

The project will be located in **Región del Libertador General Bernardo O'Higgins**.

A.4.1.3. City/Town/Community etc:

The project sites are shown in Figure A1 with specifics detailed in Table A2.

A.4.1.4. Detail of physical location, including information allowing the unique identification of this small-scale project activity(ies):



The physical location of each of the sites involved in this project activity is shown in Figure A1 and listed in Table A2.

Agricola Santa Lucia Limitada has a farm, Santa Matilde, with two sites (Quillay (1335561) and Santa Irene (32422)) in Región del Libertador General Bernardo O'Higgins. The sites are approximately 1,800 meters apart, and will share one biodigester, which is expected to be complete by 01 November 2006. Water from this biodigester will be routed to a secondary lagoon.

- Quillay is located in the city of Pichidegua, Municipality of Palmilla and is a new Site 1 (farrowing operation). The farm plans to have 2,400 sows by July 2006, 3,000 sows by December 2006, and it will reach its maximum capacity of 4,000 sows in June 2007. There are approximately 23 containment areas on site to house the animals. Waste will be removed from these areas either through flush or the pull plug method.

To remain conservative, AgCert will stagger these inventory projections over 12 months and will use only 90 percent of the projected inventory numbers for June 2007 to determine baseline emissions.

- Santa Irene is a nursing/finishing (Site 2 and Site 3) operation also located in Pichidegua, Municipality of Palmilla. By July 2006, the farm plans to have 8,280 nursers and 19,320 finishers. It's expected to house 10,350 nursers and 24,150 finishers by December 2006 and will reach its maximum capacity of 13,800 nursers and 32,200 finishers by June 2007. A total of 72 containment areas will house the animals. Waste will be removed from these areas either through flush or the pull plug method.

Because Santa Irene is undergoing a significant expansion, to remain conservative, AgCert has staggered these inventory projections over 12 months and used 90 percent of the projected inventory numbers for June 2007 to determine baseline emissions. Because the credit period start date is December 2006, and the proposed expansion will not be complete until June 2007, AgCert will prorate the first year CERs accordingly.

The producer had plans to build an anaerobic lagoon to handle the waste from these sites prior to the start of the project activity and has given AgCert documentation from a local contractor providing estimates of construction costs associated with building an open lagoon.

The producer has also secured documentation from CONAMA approving the construction of the biodigester and deeming it in accordance with good waste management practices according to Chilean law.

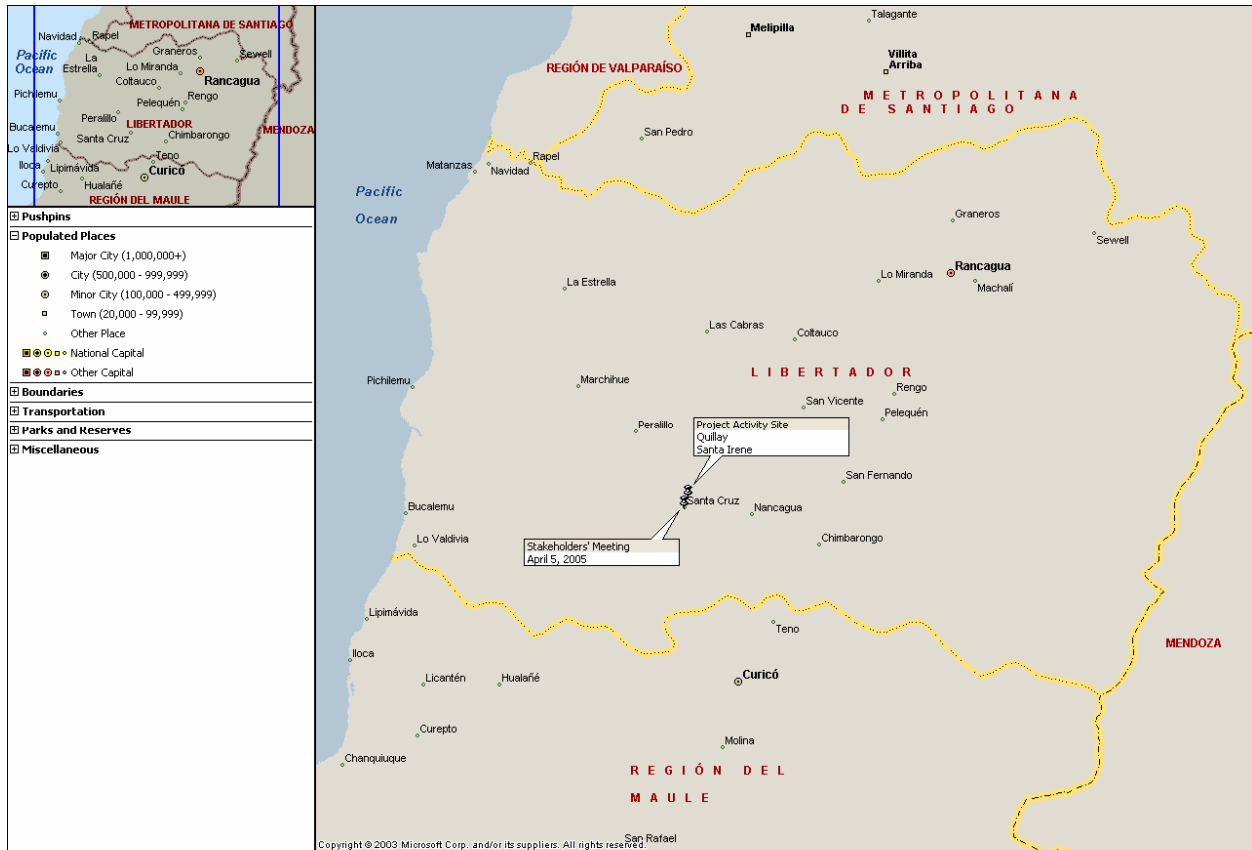

Figure A1. Región del Libertador General Bernardo O'Higgins, Chile project activity sites

**Table A2. Detailed physical location and identification of project sites**

Farm/Site Name	Address	Town/State	Contact	Phone	GPS	AgCert Site ID
Agrícola Santa Lucia Limitada	Avenida Americo Vespuccio Norte 1821, Huechuraba	Santiago, Región Metropolitana de Santiago 8320000	Raul Lyon Lopehendía	+56.2.443-7920		
Santa Irene	Fundo El Peumo, sin numero	Pichidegua, Región Libertador General Bernardo O'Higgins, 2980000	Joaquin Sanhueza	+56-72.282-5016	S 34°28 W 71°17	32422
Quillay					S 34°29 W 71°18	1335561

**A.4.2. Type and category(ies) and technology of the small-scale project activity:**

The project activity described in this document is classified as a Type III, Other Project Activities, Category III.D./Ver 10, Methane recovery in agricultural and agro industrial activities.

The project activity will capture and combust methane gas produced from the decomposing manure of swine CAFOs located in Región del Libertador General Bernardo O'Higgins, Chile.

The project activity employs technology, which includes the installation of new covered lagoons creating an anaerobic digester. The system will be comprised of a lined and covered lagoon creating a digester with sufficient capacity and Hydraulic Retention Time (HRT) to reduce the volatile solids loading in the effluent. The liner and cover consist of a synthetic high-density polyethylene (HDPE) geomembrane, which are joined together by means of an anchor trench around the perimeter. HDPE is the most commonly used geomembrane in the world and is well suited for use in this project. HDPE is an excellent product for large applications that require UV, ozone and chemical resistance. The digester has been designed to permit solids residue removal without breaking the gas retention seal.

The anaerobic digester will be heated using a biogas boiler with a liquid to liquid heat exchanger. The liquid from the digester will be pumped thru the heat exchanger to maintain a constant mesophilic temperature in the digester. Excess heated water from the boiler will be stored in an insulated water storage tank for further use in the farm buildings. Biogas overload will be removed and combusted by either a boiler or an efficient flare. Special maintenance procedures have been developed to ensure proper handling and disposition of the digester sludge.

The enclosed flaring combustion system is automated to ensure that all biogas that exits the digester and passes through the flare (and flow meter) is combusted. Pressure control devices within the gas handling system maintain proper biogas flow to the combustion system. A continuous ignition system ensures methane combustion whenever biogas is present at the flare. Two (2) sparking electrodes provide operational redundancy. If biogas is present in the flare, it is immediately ignited by the sparking system. If biogas is not present, the igniter sparks harmlessly. This continuous ignition system is powered by a robust solar module (solar-charged battery system) that operates independently from the power grid. The component parts are tested and verified functional on a periodic basis in accordance with manufacturer and other technical specifications.

Technology and know-how transfer:

The project developer is implementing a multi-faceted approach to ensure the project, including technology transfer, proceeds smoothly. This approach includes careful specification and design of a complete technology solution, identification and qualification of appropriate technology/services providers, supervision of the complete project installation, farm staff training, ongoing monitoring (by the project developer) and developing/implementing a complete Monitoring Plan using project developer staff. As part of this process, the project developer has specified a technology solution that will be self-sustaining (i.e., highly reliable, low maintenance, and operate with little or no user intervention). The materials and labour used in the base project activity are sourced from the host country whenever economically possible.

By working so closely with the project on a “day to day” basis, the project developer will ensure that all installed equipment is properly operated and maintained, and will carefully monitor the data collection



and recording process. Moreover, by working with the farm staff over many years, the project developer will ensure that the staff acquires appropriate expertise and resources to operate the system on an ongoing/continuous basis.

A.4.3. Brief explanation of how the anthropogenic emissions of anthropogenic greenhouse gas (GHGs) by sources are to be reduced by the proposed small-scale project activity, including why the emission reductions would not occur in the absence of the proposed small-scale project activity, taking into account national and/or sectoral policies and circumstances:

Anthropogenic GHGs, specifically methane is released into the atmosphere via decomposition of animal manure. Currently, the farm-produced GHG is not collected or destroyed.

The proposed project activity intends to change current AWMS practices. These changes will result in the recovery of anthropogenic GHG emissions by controlling the lagoon's decomposition processes and collecting and combusting the methane biogas.

**A.4.3.1 Estimated amount of emission reductions over the chosen crediting period:****THE TOTAL ESTIMATE OF EMISSIONS REDUCTION OVER THE RENEWABLE
7 YEAR CREDITING PERIOD**

A.4.3.1 - Estimated Emission Reductions over chosen Crediting Period	
Years	Annual estimation of emission reductions in tonnes of CO₂e
Year 1	8,240
Year 2	19,776
Year 3	19,776
Year 4	19,776
Year 5	19,776
Year 6	19,776
Year 7	19,776
Total estimated reductions (tonnes CO₂e)	126,896
Total number of crediting years	7
Annual average over the crediting period of estimated reductions (tonnes of CO₂e)	18,128

A.4.4. Public funding of the small-scale project activity:

There is no official development assistance being provided for this project.

A.4.5. Confirmation that the small-scale project activity is not a debundled component of a larger project activity:

Based on paragraph 2 of Appendix C of the Simplified Modalities and Procedures for Small-Scale CDM project activities,⁷ this project is not debundled. There are no other registered small-scale CDM project activities with the same project participants, in the same project category and technology/measure whose project boundary is within 1 km of another proposed small-scale activity.

⁷ <http://cdm.unfccc.int/EB/Meetings/007/eb7ra07.pdf>

**SECTION B. Application of a baseline methodology:****B.1. Title and reference of the approved baseline methodology applied to the small-scale project activity:**

The project activity is a Type III, Other Project Activities, Category III.D./Ver 10, Methane recovery in agricultural and agro industrial activities. The project is a small scale project because it comprises methane recovery from agro-industries, and project emissions are less than 15 kt CO₂eq.

B.2 Project category applicable to the small-scale project activity:

The simplified methodologies are appropriate because the project activity site is considered an agro-industry and GHG emissions calculations can be estimated using internationally accepted IPCC guidance.

The project activity will capture and combust methane gas produced from the decomposing manure at swine CAFOs located in Región del Libertador General Bernardo O'Higgins, Chile. This simplified baseline methodology is applicable to this project activity because without the proposed project activity, methane from the existing AWMS would continue to be emitted into the atmosphere.

B.3. Description of how the anthropogenic emissions of GHG by sources are reduced below those that would have occurred in the absence of the registered small-scale CDM project activity:

Anthropogenic GHGs, specifically methane, are released into the atmosphere via decomposition of animal manure. Currently, this farm-produced biogas is not collected or destroyed.

The proposed project activity intends to improve current AWMS practices. These changes will result in the mitigation of anthropogenic GHG emissions, specifically the recovery of methane, by controlling the lagoon's decomposition processes and collecting and combusting the biogas.

There are no existing, pending, or planned national, state, or local regulatory requirements that govern GHG emissions from agro-industry operations (specifically, pork production activities) as outlined in this PDD. The project participants have solicited information regarding this issue during numerous conversations with local and state government officials and through legal representation and have determined there is no regulatory impetus for producers to upgrade current AWMS beyond existing open air lagoon. The following paragraphs discuss the Chilean pork industry and how conditions hinder changes in AWMS practices.

Assessment of barriers:

Absent CDM project activities, the proposed project activity has not been adopted on a national or worldwide scale due to the following barriers:

- a) *Investment Barriers:* This treatment approach is considered one of the most advanced AWMS systems in the world. Only a few countries have implemented such technology because of the high costs involved in the investment compared to other available systems and due to regionalized subsidies for electric generation.

Chilean swine producers face the same economic challenges as farmers in other nations due to increased worldwide production and low operating margins. Farm owners focus on the bottom line. Odour benefits, potential water quality enhancements, and the incremental savings



associated with heating cost avoidance, are rarely enough to compel farmers to upgrade to an (expensive) advanced AWMS system.⁸ Unless the AWMS upgrade activity affords the producer the means to (partially) offset the practice change cost (via the sale of Certified Emission Reduction (CER) credits, for instance) the open lagoon will remain the common AWMS practice – *and all AWMS GHG biogas will continue to be emitted.*

Producers view the AWMS as a stage that is outside of the production process and have difficulty financing changes that should be undertaken. Even banks have been unwilling to finance such activities absent government guarantees or other incentives.

- b) *Technology barriers:* Anaerobic digester systems have to be sized to handle projected animal/effluent volumes with a Hydraulic Retention Time (HRT) consistent with reducing the amount of volatile solids content entering the system. These systems become progressively more expensive on a ‘per animal’ basis as farm animal population (i.e., farm size) is decreased. Moreover, operations and maintenance requirements involved with this technology, including a detailed monitoring program to maintain system performance levels, must also be considered. Worldwide, few anaerobic digesters have achieved long-term operations, due primarily to inappropriate operations and maintenance.
- c) *Legal barriers:* The implementation of this project activity by these farms highly exceeds current Chilean regulations for swine waste treatment. Besides existing legislation in Chile that establishes strict water quality parameters that do not allow manure to be discharged into watercourses, there is no legislation that requires a specific swine manure treatment. Currently, the government prohibits producers from discharging residual liquids to canals and/or natural water sources. For example, for dairy operations, it recommends producers use anaerobic lagoons to treat their wastewater.⁹

Per local and state officials as well as the project developer’s legal consul, there were no existing laws or regulations, nor were any anticipated, that would require these farms to change their open lagoon AWMS practice in order to mitigate GHG emissions. Approximately 50% of the farm operations in Chile have introduced the open lagoon system, in the context of the Clean Development Agreement signed in 1999 between the Government and the pork industry to enhance the level of swine manure treatment in the country. This system is attractive because of its lower cost and its consistency with the Chilean Clean Production Agreement for swine production in 1999. In 2005, a second Clean Development Agreement recommended producers include a storage system, such as an open lagoon, for liquid waste, when it would not be feasible for the liquid to be applied as irrigation. This storage system should ensure that it does not infiltrate groundwater sources.

An analysis was performed to assess whether the basis in choosing the baseline scenario is expected to change during the crediting period and the results follow:

⁸ DiPietre, Dennis, PhD, Agricultural Economist, (18 June 2003) Private communication

⁹ Cooperativa Agrícola y Lechera Santiago Ltda., Cooperativa Agrícola y Lechera Casablanca Ltda., Servicio Agrícola y Ganadero, SAG., Superintendencia de Servicios Sanitarios, SISS, Servicio de Salud Metropolitana del Ambiente, SESMA, INTEC Chile, Centro de Producción Mas Limpia, CP+L., Corporación de Fomento de La Producción, GII-CALS, CODESSER and Dirección Regional Metropolitana de CORFO; “Guía de Manejo y Buenas Prácticas para el Sector Lechero de la Zona Central;” p. 13



- a) *Legal constraints*: There is no expectation that Chilean legislation will require future use of digesters due to the *significant* investments required. Further, there is no expectation that Chile will pass any legislation which deals with the GHG emissions. Indeed, the developer is aware of no Latin American or other worldwide location requiring either the use of digesters or the constraints of agricultural GHG emissions. Qualitatively, this is the most likely “risk” area associated with possible changes in the baseline scenario. Overarching environmental regulations have to balance creating a legislative framework that enables agricultural production against social pressures to make industrialized livestock operations “good neighbours.” Chile has successfully grown this sector, building upon low operating costs and technically expert labour.
- b) *Common practice*: While past practices cannot predict future events, it is worth noting that, as stated above, about 50% of the Chilean pork production industry use open lagoons for their swine manure treatment. Such lagoons have been recognized as the technology that the government has encouraged producers to use, as stated in the Clean Production Agreement signed in 1999, which establishes the voluntary commitment of open anaerobic lagoon systems to be implemented throughout the industry.

B.4. Description of how the definition of the project boundary related to the baseline methodology selected is applied to the small-scale project activity:

The project boundary is illustrated in Figure B1. It describes the basic layout of the project farm in a schematic format. The proposed project boundary considers the GHG emissions that come from AWMS practices, including the GHG resulting from the capture and combustion of biogas. The project activity site uses a system of one or more lagoons. Proposed AWMS practice changes include the construction of an ambient temperature digester comprised of cells that capture the resulting bio-gas which is then combusted. Based on the methodology, the anaerobic digester is the physical boundary of the methane recovery facility.

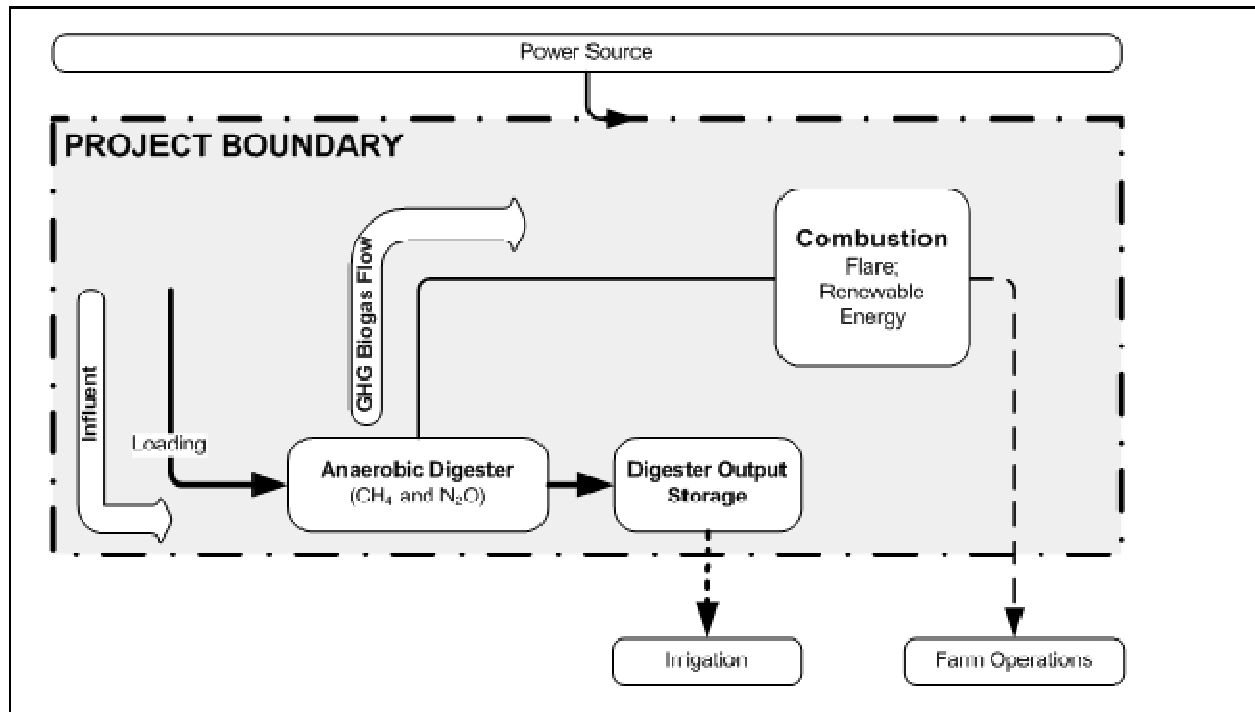

Figure B1. Project Boundary

B.5. Details of the baseline and its development:

The amount of methane that would be emitted to the atmosphere in the absence of the project activity can be estimated by referring to Section 4.2.5 of the Revised 1996 IPCC Guidelines for National GHG Inventories.

The final draft of this baseline section was completed on 20/09/2006. The name of entity determining the baseline is AgCert. AgCert is a project participant, as well as the project developer.

The baseline for this project activity is defined as the amount of methane that would be emitted to the atmosphere during the crediting period in the absence of the project activity. In this case an open anaerobic lagoon is considered the baseline and estimated emissions are determined as follows:

Step 1 – Animal Population

Animal populations for the project activity sites are described in the Section E.1.2.1, Table E1. The AWMS used on the farms is an open anaerobic lagoon, unless otherwise noted in Section A.4.1.4.

Step 2 – Emission Factors

The emission factor for the animal group for any given month is:



$$EF_i = VS_i * n_m * B_{0i} * 0.67\text{kg/m}^3 * MCF_{jk} * MS\%_{ijk}$$

Equation B1¹⁰

Where:

- EF_i = emission factor (kg) for animal type i (e.g., swine, weight adjusted),
- VS_i = Volatile solids excreted in kg/day for animal type I, max Vs is 0.5 kg/head/day (adjusted as $Vs = (W_{\text{site}}/W_{\text{default}})^{11} * VS_{\text{IPCC}}$)
- n_m = Number of days animals present,
- B_o = Maximum methane producing capacity (m^3/kg of VS) for manure produced by animal type i,
- MCF_{jk} = Methane conversion factor for each manure management system j by climate region k; and
- $MS\%_{ijk}$ = fraction of animal type i's manure handled using manure system j in climate region k.

The amount of methane emitted can be calculated using:

$$CH_{4a} = EF_i * Population_{\text{year}}$$

Equation B2¹²

Where:

- CH_{4a} = methane produced in kg/yr for animal type I,
- EF_i = emission factor (kg) for animal type i (e.g., swine),
- $Population_{\text{year}}$ = yearly average population of animal type i.

Step 3 – Total Baseline Emissions

To estimate total yearly methane emissions the selected emission factors are multiplied by the associated animal population and summed.

¹⁰ Revised 1996 IPCC Guidelines for National Greenhouse Gas Inventories: Reference Manual. Page 4.26, equation 16 and Page 4.46, Table B6.

¹¹ Obtained from 1996 IPCC, Appendix B, Table B-6, p. 4.46

¹² Adapted from Revised 1996 IPCC Guidelines for National Greenhouse Gas Inventories: Reference Manual. Page 4.26.



$$BE = [CH_{4a} * GWP_{CH4}]/1000$$

Equation B3¹³

Where:

- BE* = Baseline carbon dioxide equivalent emission in metric tons per year,
CH_{4a} = annual methane produced in kg/yr for animal type I,
GWP_{CH4} = global warming potential of methane (21).

SECTION C. Duration of the project activity / Crediting period:

C.1. Duration of the small-scale project activity:

C.1.1. Starting date of the small-scale project activity:

The starting date for this activity is 10/04/2006

C.1.2. Expected operational lifetime of the small-scale project activity:

The expected life of this project is 22y – 07m

C.2. Choice of crediting period and related information:

The project activity will use a **renewable** crediting period

C.2.1. Renewable crediting period:

C.2.1.1. Starting date of the first crediting period:

The starting date of the first crediting period is 01/01/2007.

C.2.1.2. Length of the first crediting period:

The length of the first crediting period is **7y-0m**.

C.2.2. Fixed crediting period:

C.2.2.1. Starting date:

¹³ Adapted from Equation 9, page 12, AM0016/version 02, 22 October 2004 / UNFCCC / CDM Meth Panel

**C.2.2.2. Length:****SECTION D. Application of a monitoring methodology and plan:****D.1. Name and reference of approved monitoring methodology applied to the small-scale project activity:**

The methodology applied to this project activity is AMS-III.D./Ver 10, Methane recovery in agricultural and agro industrial activities.

D.2. Justification of the choice of the methodology and why it is applicable to the small-scale project activity:

The simplified monitoring methodologies are applicable to this project activity because they provide a method to accurately measure and record the GHG emissions that will be captured and combusted by the project activity.

D.3 Data to be monitored:

See Table D1 for specific parameters to be monitored.



Table D1. Data to be monitored

ID number	Data type	Data variable	Data unit	Measured (m), calculated (c) or estimated (e)	Recording frequency	Proportion of data to be monitored	How will the data be archived?	For how long is archived data to be kept?	Comment
1. BGP	Volume	Biogas produced	m ³	m	Monthly	100%	electronic	Duration of project activity +2y	This parameter measures cumulative biogas produced. A biogas meter will continuously measure amount of biogas produced.
2. MC	Percent	Methane content	%	m	Quarterly	100%	electronic	Duration of project activity +2y	This parameter determines the methane content of the biogas.
3. CEE	Volume	Biogas produced	m ³	m/c	As needed	n/a	electronic	Duration of project activity +2y	Whenever the flare is observed to be out of service, any biogas metered from the last recorded operational point in time, shall be excluded from the total Biogas reading (ID: 1. BGP)
4.FE	Percent	Efficiency of Flaring	%	m/c	Once	n/a	Electronic or paper	Duration of project activity +2y	AgCert staff will sample test flare efficiency periodically to ensure that enclosed flares are achieving complete methane destruction.

**D.4. Qualitative explanation of how quality control (QC) and quality assurance (QA) procedures are undertaken:**

AgCert has designed and implemented a unique set of data management tools to efficiently capture and report data throughout the project lifecycle. On-site assessment (collecting Geo-referenced, time/date stamped data), supplier production data exchange, task tracking, and post-implementation auditing tools have been developed to ensure accurate, consistent, and complete data gathering and project implementation. Sophisticated tools have also been created to estimate/monitor the creation of high quality, permanent, ERs using IPCC formulae.

By coupling these capabilities with an ISO quality and environmental management system, AgCert enables transparent data collection and verification.

D.5. Please describe briefly the operational and management structure that the project participant(s) will implement in order to monitor emission reductions and any leakage effects generated by the project activity:

A complete set of procedures and a Monitoring Plan (Annex 3) has been developed to ensure accurate measurement of biogas produced and proper operation of the digester equipment. This plan exceeds the requirements outlined in the approved methodology outlined in Appendix B of the simplified modalities and procedures for small-scale CDM project activities as it applies to proposed project activity.

Metering devices used are designed to continuously and accurately measure biogas flow and are specially designed for corrosive environments. Meters are received from the factory fully-calibrated and retain calibration for the service life of the unit. Volumetric accuracy of the meter is permanent and non-adjustable. Accuracy is not affected by low or varying line pressures. Accuracy of the flowmeters utilized exceeds 99 percent across the entire measured rate curve with an uncertainty range of less than \pm 1 percent. Periodic maintenance will be performed based on manufacturer specifications. Other equipment calibrations are accomplished using procedures developed by the project developer (Annex 4).

Methane concentration is determined using a Bacharach Model Fyrite (or equivalent) gas analyzer. The process is described in the Monitoring Plan. The measuring equipment is calibrated in accordance with the manufacturer specifications. The equipment is accurate to within 0.5%.

Further, AgCert has a trained staff located in the host nation to perform O&M activities including but not limited to monitoring and collection of parameters, quality audits, personnel training, and equipment inspections. The associated Monitoring Plan has been developed to provide guidance (work instructions) to individuals that collect and/or process data. AgCert staff will perform audits of farm operations personnel on a regular basis to ensure proper data collection and handling.

D.6. Name of person/entity determining the monitoring methodology:

The entity determining this monitoring methodology is AgCert, who is the project developer listed in Annex 1 of this document.

SECTION E.: Estimation of GHG emissions by sources:

**E.1. Formulae used:****E.1.1 Selected formulae as provided in appendix B:**

Specific formula to calculate the GHG emission reductions by sources for the AWMS improvement are not provided in appendix B of the simplified M&P for small-scale CDM project activities.

E.1.2 Description of formulae when not provided in appendix B:**E.1.2.1 Describe the formulae used to estimate anthropogenic emissions by sources of GHGs due to the project activity within the project boundary:**

The amount of methane that would be emitted to the atmosphere due to the project activity and within the project boundaries can be estimated by referring to Section 4.2.5 of the Revised 1996 IPCC Guidelines for National GHG Inventories

The project emissions for this project activity are defined as the amount of methane that would be emitted to the atmosphere during the crediting period due to the project activity. In this case an anaerobic digester is considered the project activity and estimated emissions are determined as follows:

Step 1 – Animal Population

Animal populations for the project activity sites are described in the tables below. The AWMS proposed for use on the farm is an anaerobic digester.



Table E1, Animal Populations

	Month/Yr	Animal Type				
		Sow	Gilt	Boar	Fin	Nurs
Quillay (1335561)	Projected Inventory	2,400	100	33	0	0
		2,400	100	33	0	0
		2,400	100	33	0	0
		2,400	100	33	0	0
		3,000	200	66	0	0
		3,000	200	66	0	0
		3,000	200	66	0	0
		3,000	200	66	0	0
		3,600	300	100	0	0
		3,600	300	100	0	0
		3,600	300	100	0	0
		3,600	300	100	0	0
As Quillay is a new site, the inventory numbers provided reflect a conservative estimate for 12 months and take into consideration the producer's planned expansion through June 2007.						
	Month/Yr	Animal Type				
		Sow	Gilt	Boar	Fin	Nurs
Santa Irene (32422)	Projected Inventory	0	0	0	19,320	8,280
		0	0	0	19,320	8,280
		0	0	0	19,320	8,280
		0	0	0	19,320	8,280
		0	0	0	24,150	10,350
		0	0	0	24,150	10,350
		0	0	0	24,150	10,350
		0	0	0	24,150	10,350
		0	0	0	28,980	12,420
		0	0	0	28,980	12,420
		0	0	0	28,980	12,420
		0	0	0	28,980	12,420
Santa Irene is currently undergoing an expansion, and this table conservatively reflects projected inventory numbers through June 2007.						

Step 2 – Emission Factors

The emission factor for the animal group for any given month is:



$$EF_i = VS_i * n_m * B_{oi} * 0.67\text{kg/m}^3 * MCF_{jk} * MS\%_{ijk}$$

Equation E2¹⁴

Where:

- EF_i = emission factor (kg) for animal type i (e.g., swine, weight adjusted),
- VS_i = Volatile solids excreted in kg/day for animal type I, max Vs is 0.5 kg/head/day (adjusted as $V_s = (W_{\text{site}}/W_{\text{default}})^{15} * VS_{\text{IPCC}}$)
- n_m = Number of days animals present,
- B_o = Maximum methane producing capacity (m^3/kg of VS) for manure produced by animal type i,
- MCF_{jk} = Methane conversion factor for each manure management system j by climate region k; and
- $MS\%_{ijk}$ = fraction of animal type i's manure handled using manure system j in climate region k.

The amount of methane emitted can be calculated using:

$$CH_{4a} = EF_i * Population_{\text{year}}$$

Equation E3¹⁶

Where:

- CH_{4a} = methane produced in kg/yr for animal type I,
- EF_i = emission factor (kg) for animal type i (e.g., swine),
- $Population_{\text{year}}$ = yearly average population of animal type i.

E.1.2.2 Describe the formulae used to estimate leakage due to the project activity, where required, for the applicable project category in appendix B of the simplified modalities and procedures for small-scale CDM project activities

In accordance with the baseline methodology, leakage calculations are not required.

¹⁴ Revised 1996 IPCC Guidelines for National Greenhouse Gas Inventories: Reference Manual. Page 4.26, equation 16 and Page 4.46, Table B6.

¹⁵ Obtained from 1996 IPCC, Appendix B, Table B-6, p. 4.46

¹⁶ Adapted from Revised 1996 IPCC Guidelines for National Greenhouse Gas Inventories: Reference Manual. Page 4.26.

**E.1.2.3 The sum of E.1.2.1 and E.1.2.2 represents the small-scale project activity emissions:**

To estimate total yearly methane emissions the selected emission factors are multiplied by the associated animal population and summed.

$$PE = [CH_{4a} * GWP_{CH4}]/1000 + DE$$

Equation E4¹⁷

Where:

- PE* = Project activity carbon dioxide equivalent emission in metric tons per year,
CH_{4a} = annual methane produced in kg/yr for animal type I,
GWP_{CH4} = global warming potential of methane (21),
DE = direct emissions from use of fossil fuels/electricity for operation of facility¹⁸

Source per site	Est kwh consumed/produced per yr	kg CO2e emitted per kwh produced - Chile	metric tonnes CO2e per site
Direct Emissions from electricity/fossil fuel	16,331	0.2740	4.47

Table E2. Project Activity Emissions (Methane shown in metric tonnes of CO₂e)

Project Activity Emissions			
Legal Entity	Site	Site ID	CH4
Agricola Santa Lucia Limitada	Quillay	1335561	377
Agricola Santa Lucia Limitada	Santa Irene	32422	2,095
Total:			2,473

¹⁷ Adapted from Equation 9, page 12, AM0016/version 02, 22 October 2004/UNFCCC/CDM Methodology Panel

¹⁸ Direct emissions calculated using country specific factors from The GHG Indicator: UNEP Guidelines for Calculating Greenhouse Gas Emissions for Businesses and Non-Commercial Organisations, Appendix 8.2, Table 12 (1996 calculation) http://www.uneptie.org/energy/tools/ghgin/docs/GHG_Indicator.pdf



E.1.2.4 Describe the formulae used to estimate the anthropogenic emissions by sources of GHGs in the baseline using the baseline methodology for the applicable project category in appendix B of the simplified modalities and procedures for small-scale CDM project activities:

Table E3. Baseline Emissions (Methane shown in metric tonnes of CO₂e)

Baseline Emissions			
Legal Entity	Site	Site ID	CH ₄
Agricola Santa Lucia Limitada	Quillay	1335561	3,396
Agricola Santa Lucia Limitada	Santa Irene	32422	18,858
Total:			22,254

E.1.2.5 Difference between E.1.2.4 and E.1.2.3 represents the emission reductions due to the project activity during a given period:

Table E4. Total Emission Reductions

Total Emission Reductions	
	CO ₂ e/year
Total Baseline Emissions (BE)	22,254
Project Emissions (PE)	2,473
Direct emissions from electricity/fossil fuel (PE)	5
Total Emission Reductions (ER_{net} = BE - PE)	19,776

*First year will be prorated by 7 months (the time between the credit period start date and when farm will reach full capacity)

E.2 Table providing values obtained when applying formulae above:

Table E5.

Parameter/Factor	Value	Source/Comment
Baseline		
GWP CH ₄	21	Intergovernmental Panel on Climate Change, <i>Climate Change 1995: The Science of Climate Change</i> (Cambridge, UK: Cambridge University Press, 1996)
Population _{year}	Table E1	Animal population used to estimate baseline and project emission estimates was based on a 12 month period of actual or projected operation production data (See Table E1).
n _m	Table E1	Days resident in system
MS% _{ijk}	100%	Percent of effluent used in system.
VS _i	0.50	Obtained from 1996 IPCC, Appendix B, Table B-6, p. 4.46



Parameter/Factor	Value	Source/Comment
B_{oi}	0.45	Obtained from 1996 IPCC, Appendix B, Table B-6, p. 4.46
MCF_{jk}	0.90	Obtained from 1996 IPCC, Appendix B, Table B-6, p. 4.46
Project Activity		
GWP CH ₄	21	Intergovernmental Panel on Climate Change, <i>Climate Change 1995: The Science of Climate Change</i> (Cambridge, UK: Cambridge University Press, 1996)
Population _{year}	Table E1	Animal population used to estimate baseline and project emission estimates was based on a 12 month period of actual or projected operation production data (See Table E1).
n_m	Table E1	Days resident in system
MS% _{ijk}	100%	Percent of effluent used in system
VS _i	0.50	Obtained from 1996 IPCC, Appendix B, Table B-6, p. 4.46
B_{oi}	0.45	Obtained from 1996 IPCC, Appendix B, Table B-6, p. 4.46
MCF_{jk}	0.10	Obtained from 1996 IPCC, Appendix B, Table B-6, p. 4.46

Table E6.

Uncertainty Parameter for GHG Mitigation Project Estimates	
Uncertainty:	How Addressed:
<ul style="list-style-type: none"> ○ Data collection inaccuracies ○ Animal type ○ Animal population, group/type, mortality rates ○ Genetics ○ Choice of appropriate emission coefficients ○ Data security ○ Animal health 	<ul style="list-style-type: none"> ○ Accurate data collection is essential. The farms included in this project activity use a Standardized industry database package which captures a wide range of incremental production data to manage operations and enable the farm to maximize both productivity and profitability. AgCert uses some data points collected via this system. ○ AgCert has a rigorous QA/QC system that ensures data security and data integrity. AgCert performs spot audits data collection activities. ○ AgCert has a data management system capable of interfacing with producer systems to serve as a secure data repository. Project activity data related uncertainties will be reduced by applying sound data collection quality assurance and quality control procedures. ○ Any significant mortality rates will be visible from the Monthly Monitoring Form and addressed accordingly.

SECTION F.: Environmental impacts:

F.1. If required by the host Party, documentation on the analysis of the environmental impacts of the project activity:

Environment:

There are no negative environmental impacts resulting from the proposed project activity.



Beyond the principal benefit of mitigating GHG emissions (the primary focus of the proposed project); the proposed activities will also result in positive environmental co-benefits. They include:

- Reducing atmospheric emissions of Volatile Organics Compounds (VOCs) that cause odour,
- Lowering the population of flies and associated enhancement to on-farm bio-security thus reducing the possible spread of disease.

The combination of these factors will make the proposed project site more “neighbour friendly” and environmentally responsible

SECTION G. Stakeholders’ comments:

G.1. Brief description of how comments by local stakeholders have been invited and compiled:

AgCert invited stakeholders to a regional meeting to explain the UNFCCC CDM process and proposed project activity, presided over by Julio Hill, a representative of AgCert Chile. Invitations were sent to governmental, and NGO invitees via post and electronic mail. This meeting took place in Santa Cruz,, Región IV, Del Libertador Bernardo O’Higgins on April 5, 2005.

Additionally, public notifications regarding the meeting were published, in Spanish, in a local newspaper prior to the meeting so that community members would be aware of the gathering:

1. *El Cóndor*, Santa Cruz, March 23, 2005
2. *El Cóndor*, Santa Cruz, March 30, 2005
3. *El Cóndor*, Santa Cruz, April 2, 2005

Representatives from the local community as well as the state level were also invited. A slide presentation was given, in Spanish, and attendees were afforded the opportunity to ask questions and provide comments. Also presented were processes and responsibilities of the project participants, equipment to be used for evaluation and audits, information management system, an example of project, benefits from the project (environmental and economic), and where to get further information.

G.2. Summary of the comments received:

Overall, the comments from the attendees at the stakeholders’ meeting were positive and supportive of the project.

G.3. Report on how due account was taken of any comments received:

No action required.

**Annex 1****CONTACT INFORMATION ON PARTICIPANTS IN THE PROJECT ACTIVITY.**

Project Developer and Participant:	
Organization:	AgCert International plc
Street/P.O. Box:	Blackthorn Road Sandyford
Building:	Apex Building
City:	Dublin 18
State/Region:	
Postfix/ZIP:	18
Country:	Ireland
Telephone:	
FAX:	
E-Mail:	
URL:	www.agcert.com
Represented by:	
Title:	CDM/JI Program Manager
Salutation:	Mr.
Last Name:	Perkowski
Middle Name:	S.
First Name:	Leo
Department:	Business Development
Mobile:	+1 (321) 432.3081
Direct FAX:	+1 (353) 245-7400
Direct tel:	
Personal E-Mail:	lperkowski@agcert.com
Project Participant:	
Organization:	AgCert Chile Servicios Ambientales Limitada
Street/P.O. Box:	Av. Las Condes 7260
Building:	
City:	Santiago
State/Region:	
Postfix/ZIP:	
Country:	Chile
Telephone:	
FAX:	
E-Mail:	
URL:	www.agcert.com
Represented by:	
Title:	Project Coordinator
Salutation:	Mr.
Last Name:	Lawrence
Middle Name:	
First Name:	Dave
Department:	Business Development
Mobile:	
Direct FAX:	+55 11 - 2127.0550
Direct tel:	55 11 – 2127.0487
Personal E-Mail:	dlawrence@agcert.com



Annex 2

INFORMATION REGARDING PUBLIC FUNDING

There is no official development assistance being provided for this project.



Annex 3

Monitoring Plan

PURPOSE

The purpose of this method specification is to describe the criteria for maintaining equipment, reporting equipment outages, and to provide detailed guidance for collection and processing of data that is used in the determination of Green House Gas (GHG) emissions.

SCOPE

This document applies to GHG Mitigation Project related activities. It applies to all personnel that operate and/or maintain project activity equipment and/or have an active role in data collection and processing.

ASSOCIATED DOCUMENTS

- UNFCCC approved monitoring methodology: AMS-III.D., Methane Recovery.
http://cdm.unfccc.int/UserManagement/FileStorage/CDMWF_AM_PF50DGZMOZM6QBRHQ3PW_WSKEKCLSV2
- Jody Zall Kusek, and Ray C. Rist, June 2004. Ten Steps to a Results-based Monitoring and Evaluation System: A Handbook for Development Practitioners, World Bank.
http://www.worldbankinfoshop.org/ecommerce/catalog/product?item_id=3688663
- Component guides / manuals for:
 - Manure transfer system
 - Ambient temperature anaerobic digester
 - Biogas transfer system including a biogas flow-meter
 - Combustion system (Flare)
 - Optional combustion system (Electrical Generator)
- MS004-F1, O & M Weekly Monitoring Checklist
- MS004-F2, O & M Monthly Monitoring Form
- MS004-F3, O & M Maintenance Log (en-br)
- MS004-F4, O & M Maintenance Log (sp-mx)
- MS008, Farm Data Collection Procedure
- MS008-F1, Animal Inventory Control



- MS008-F2, Monthly Inventory Reporting
- P004, Control of Nonconforming Product/Service
- P020, Monitoring & Measurement of Product/Processes
- P025, Control of Monitoring & Measurement Devices
- I025-1, Equipment Calibration & Verification
- P039, Competence, Training, and Awareness
- I031-2F11, Form B – Swine – IPCC (en)
- I031-2F13, Form B – IPCC – MX (sp)
- I031-2F16, Form B – Dairy – IPCC (en), (sp), (pt)
- I036-9, Bio-security and Safety
- Operations Manual CO₂ Analyzer
- EnviroCert Operations Management System (OMS)

OPERATION AND MAINTENANCE ACTIVITIES

System Overview

The Animal Waste Management System (AWMS) used in this project is shown in Figure 1. The system is made up of four (4) major system components:

- Manure transfer system which includes one lift station if needed
- Ambient temperature anaerobic digester cell(s)
- Biogas transfer system including a biogas flow-meter
- Combustion system (Flare)
- Optional combustion system (Electrical Generator)

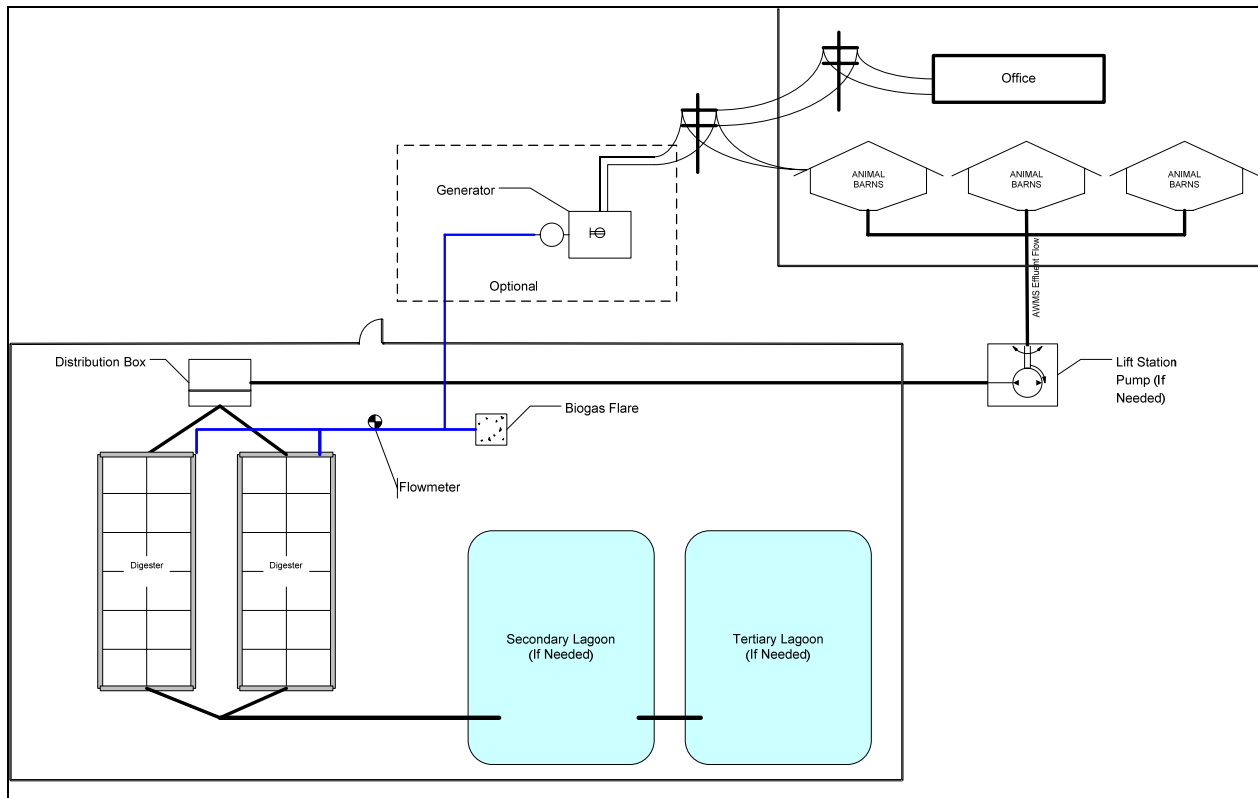

Figure 1. Typical GHG Mitigation Project System Overview

System Components Operation Requirements

Manure Transfer System

Training

Training on the Manure Transfer System shall be provided to the operations personnel by the system manufacturer and installer. Training shall include: system components, normal operation, emergency operations, maintenance, and request for warranty service. Training on reporting procedures shall be provided to the productions operations manager by AgCert.

Normal Operation

The system described in Figure 1 is a typical flush system with one optional lift station. Under normal conditions, farm hands clean the manure from the barns using water hoses and squeegees. This effluent is captured and then flushed from the barns periodically. Effluent from the barns is deposited in a lift station. Upon reaching predetermined threshold, the pump engages and routes the effluent to the digester cell. Upon being treated in the digester, the effluent is then routed from the digester to the storage lagoon. Liquid from the lagoon can then be used for irrigation.

Safety Issues and Emergency Preparedness

Care should be exercised when working around the lift station and distribution box (if installed) to avoid falling into the pit.



Weekly Inspection

A periodic inspection shall include the following:

- Check for pipeline obstructions
- Check for leaks in exposed pipelines
- Check for corrosion at exposed joints

Alternative Operating Procedures

In the event the manure transport system becomes unusable, the farm manager shall notify AgCert in accordance with paragraph 0. Both parties shall work together to reach an acceptable alternate method to route the effluent so that farm operations are not affected, and GHG continues to be captured. If maintenance or warranty service is required, AgCert shall contact the appropriate service provider. Upon restoration of the system the farm manager shall notify the Regional Maintenance Technician (RMT) (phone, e-mail, etc.).

Ambient Temperature Anaerobic Digester

WARNING

The gas contained in the digester cell is EXTREMELY flammable. Sources of ignition and smoking are not permitted within 10 meters of the cell and gas handling system.

Death or serious injury may result.

Training

Training on the Ambient Temperature Anaerobic Digester shall be provided to production operations personnel by the system manufacturer and installer. Training shall include: system components, start-up procedures, normal operation, emergency operations, maintenance, and request for service. Training on reporting procedures shall be provided to the productions operations personnel by AgCert.

Startup Procedures

Refer to the guide / manual for the ambient temperature anaerobic digester.

Loading Rate and Total Solids Content

Refer to the guide / manual for the ambient temperature anaerobic digester.

Normal Operation

Refer to the guide / manual for the ambient temperature anaerobic digester.

Safety Issues and Emergency Preparedness

- No open flame permitted within 10 meters of the digester



- Do not allow personnel to stand, sit, or lean against the digester cover
- Do not use sharp objects/tools in the vicinity of the cover

Weekly Inspection

A weekly inspection shall include the following:

- Cover material – check for cracks, tears, or points of distress around perimeter of digester cell.
- Check for excessive ballooning of cover or presence of odor
- Check seams for signs of gas leakage

Alternative Operating Procedures

In the event the digester cell becomes unusable, the farm manager shall notify AgCert in accordance with paragraph 0. Both parties shall work together to reach an acceptable alternate method to treat the effluent so that farm operations are not affected, and GHG gas continues to be captured. If maintenance or warranty service is required, AgCert shall contact the appropriate service provider. Upon restoration of the system the Regional Maintenance Technician shall be notified (phone, e-mail, etc.).

Biogas Transfer System and Biogas Sensor/Flow-Meter

Training

Training on the Biogas Transfer System shall be provided to the operations personnel by the system manufacturer and installer. Training shall include: system components, normal operation, emergency operations, maintenance, and request for warranty service. Training on reporting procedures shall be provided to the production operations personnel by AgCert.

Normal Operation

Biogas produced in the anaerobic digester is trapped under a positive or negative pressure geomembrane cover installed over the digester cell. The biogas is routed from the digester to the flare via PVC tubing.

A flow meter, which measures gas flow, is fitted in the biogas transfer system piping.



Figure 2. Roots biogas flowmeter

Safety Issues and Emergency Preparedness

Gas to the metering system should be disconnected prior to performing maintenance on the flow-meter. Care should be taken when digging in the area where the pipeline is buried.

Preventive Maintenance

Preventive maintenance shall be conducted in accordance with manufacturer’s recommendations. NOTE: A record of the cumulative biogas reading must be recorded prior to zeroing the meter.

Weekly Inspection

The weekly inspection shall include the following:

- Check for leaks in exposed pipelines



- Check for proper operation of the flow-meter

Alternative Operating Procedures

In the event that the biogas transfer system becomes unusable; the farm manager shall **immediately** notify AgCert in accordance with paragraph 0. Both parties shall work together to reach an acceptable alternate method to route the biogas so that farm operations are not affected and GHG gas emissions are mitigated. If maintenance or warranty service is required, AgCert shall contact the appropriate service provider. Upon restoration of the system the RMT shall be notified (phone, e-mail, etc.).

Combustion System (Flare)

Training

Training on the Flare Combustion System shall be provided by the system manufacturer and installer. Training shall include: system components, normal operation, emergency operations, maintenance, and request for warranty service. Training on reporting procedures shall be provided to the production operations personnel by AgCert.

Normal Operation

The flare system is designed to combust the biogas whenever it is present. AgCert's flaring combustion system is automated to ensure that all biogas that exits the digester and passes through the flare (and flow meter) is combusted. Pressure control devices within the gas handling system maintain proper biogas flow to the combustion system. A continuous ignition system ensures methane combustion whenever biogas is present at the flare. The continuous ignition system is powered by a robust solar module (solar-charged battery system) that operates independently from the power grid. These solar modules are designed for rigorous outdoor application in remote locations and are proven through many years of operational experience in ranch and farm settings similar to AgCert project sites. Two (2) sparking electrodes provide operational redundancy to ensure that a minimum of one (1) spark is produced at the flare burner every 3 seconds. If biogas is present in the flare, it is immediately ignited by the sparking system. If biogas is not present, the igniter sparks harmlessly.

Safety Issues and Emergency Preparedness

Prior to performing any maintenance on the flare system, the gas flow **must** be turned off. Care should be exercised when working around the flare system as components can be extremely hot.

Preventive Maintenance

Preventive maintenance shall be conducted at least yearly in accordance with component manufacturer's recommendations.

Weekly Inspection

The weekly inspection shall include a visual inspection to determine the flare is combusting gas.

Alternative Operating Procedures

In the event that the flare system becomes unusable, the farm manager shall **immediately** notify AgCert in accordance with paragraph 0. Both parties shall work together to reach an acceptable alternate method to combust the biogas so that farm operations are not affected and GHG emissions are mitigated. If maintenance or warranty service is required, AgCert shall contact the appropriate service provider. Upon restoration of the system the RMT shall be notified (phone, e-mail, etc.).



Optional Combustion System

Training

Training on any optional combustion system, e.g., generator, space heater, etc., shall be provided by the system manufacturer and installer. Training shall include: system components, normal operation, emergency operations, maintenance, and request for warranty service. Training on reporting procedures shall be provided to the production operations personnel by AgCert.

Normal Operation

An optional combustion system is designed to take advantage of the biogas and convert it into renewable energy. The systems can be used to generate electricity, heat a barn, or any other process approved (in writing) by AgCert and the verifying designated operational entity (DOE).

Safety Issues and Emergency Preparedness

Prior to performing any maintenance on an optional combustion system, the gas flow **must** be turned off. Care should be exercised when working around the optional combustion system as components can be extremely hot and high voltage may be present (when operating).

Preventive Maintenance

Preventive maintenance shall be conducted in accordance with manufacturer’s recommendations. NOTE: In any case where it is required to zero and/or remove a meter, ensure that the meter reading is noted prior to zeroing and/or removing the meter.

Alternative Operating Procedures

In the event that the generator system becomes unusable, the user shall notify AgCert in accordance with paragraph 0. The flare shall be used as the only method to combust GHG biogas. The user shall take appropriate action to notify his service provider should maintenance or warranty service be required. Upon restoration of the system the RMT shall be notified (phone, e-mail, etc.).

Maintenance, Trouble Reporting and Documentation

Emergency Maintenance:

Situations requiring immediate attention due to failure of components of the digester or combustion system that could cause significant damage to the physical structure, or could result in the release of GHG or failure to capture GHG should be immediately reported to the Regional Maintenance Technician. If unavailable, contact the National Monitoring or Maintenance Manager of the country where the equipment is located or the International Operations and Maintenance Manager.

Title	Phone	e-mail
Regional Maintenance Technician (RMT)	Supplied during training	Supplied during training
Argentina National Monitoring Manager		operationsar@agcert.com



Brazil National Monitoring Manager	(11) 5522 6940	operationsbr@agcert.com
Chile National Monitoring Manager		operationscl@agcert.com
International Monitoring Manager	+1.321.409.7846	operations@agcert.com
Mexico National Monitoring Manager	(55) 5557 1750	operationsmx@agcert.com

Unscheduled Maintenance:

Situations requiring maintenance (not resulting in the release or failure to capture GHG) should be reported to the Regional Maintenance Technician, normally within 1 to 24 hours of discovery.

Records Keeping

Maintenance and servicing of equipment shall be recorded.

MONITORING ACTIVITIES

The following table summarizes key parameters monitored:

Table 1. Key parameters monitored

ID	Item	Applies to Project	Monitored		ER Calculation Data		Performed by	Comments
			Ex-ante	Ex-post	Primary	Secondary		
1	Biogas Produced (BGP)	✓		✓		✓	FH, RMT	QA/QC
2	Methane Content (MC)	✓		✓		✓	RMT	QA/QC
3	Combustion System Operational Time (CEE)	✓		✓	✓		FH, RMT	Whenever the flare is observed to be out of service, any biogas metered from the last known operational point in time, shall be deducted from the total Biogas reading
4	%FE	✓		✓				Ensures correct performance of combustion

Farm: FH – Farm Hand; DP – Data Processor; FM – Farm Manager;
AgCert: RMT – Regional Maintenance Technician, QA – Quality Assurance; OP – Operations, EN - Engineer



MONITORING WORK INSTRUCTIONS

Work instructions for the monitoring of key parameters can be found on the following pages:

Work Instruction for monitoring ID 1, Biogas Produced

Summary

This ID monitors the volume and flow of biogas sent to the combustion system on a monthly basis. It is a quality control check to ensure proper operation of the anaerobic digester.

References

- UNFCCC approved monitoring methodology: AMS-III.D., Methane Recovery.
- Data collection forms (provided by farm manager)
- P025, Control of Monitoring and Measuring Device (MMD)
- MS004-F2, O & M Monthly Monitoring Form

Prerequisite(s)

Processes

- I036-9, Bio-security and Safety

Training of Monitoring Personnel

- Regional Maintenance Technicians and operations personnel shall be trained on data collection transfer processes.

Equipment, Materials and Tools

- Biogas Flow Meter

Calibration

- Prior to using a measuring device, ensure it is calibrated.

Process

Step	Operator	Activity	Documentation	Comments
1	RMT	Record reading in appropriate area of MS004-F2, Monthly Monitoring Form	MS004-F2, Monthly Monitoring Form	
2	RMT	Transmit data to MLB operations	Fax, Electronic, etc	Enter data into EnviroCert
3	QA	Perform Quality Control Check for format, integrity, etc.		
4	OP	Confirm reading within expected limits IAW manufacturer guidelines.		



Step	Operator	Activity	Documentation	Comments
5	OP	Store Data		
Farm: FH – Farm Hand; DP – Data Processor; FM – Farm Manager; AgCert: RMT – Regional Monitoring Technician, QA – Quality Assurance; OP – Operations, EN – Engineer				

Records Control

RECORD ID	RECORD LOCATION	RETENTION TIME	DISPOSITION
MS004-F2, Monthly Monitoring Form	Document Control Center	Duration of project + 2 years	Destroy

Work Instruction for monitoring ID 2, Methane Content

Summary

This ID determines the methane content of the biogas. It is a snapshot of the AMWS methane production efficiency. Methane concentration is determined with CO₂ content measurement and is obtained with a gas analyzer. A range of $\pm 10\%$ points is sufficient to determine uncertainties. For example, the nominal percentage of CH₄ in biogas is approximately 65%. Readings between 55% and 75% indicate proper operation of the digester. The measuring equipment is calibrated in accordance with the manufacturer specifications.

References

- UNFCCC approved monitoring methodology: AMS-III.D., Methane Recovery
- P025, Control of Monitoring and Measuring Device (MMD)
- Operations Manual CO₂ Analyzer
- MS004-F2, Monthly Monitoring Form
- MS004-F3 or F4, O & M Maintenance Log

Prerequisite(s)

Processes

- I036-9, Bio-security and Safety



Training of Monitoring Personnel

- Operating the CO₂ Analyzer
- Regional Maintenance Technicians shall be trained on data collection transfer processes.
- Operations personnel shall be trained on data processing and storage

Equipment, Materials and Tools

- CO₂ Analyzer

Calibration

- As required by the manufacturer.



Process

Step	Operator	Activity	Documentation	Comments
1	RMT	Prepare the gas analyzer as directed in the operator manual.	CO ₂ Analyzer Operations Manual	
2	RMT	Connect the CO ₂ analyzer to the system test port.		
3	RMT	Open valve on test port		
4	RMT	Take gas reading in accordance with Operations Manual		Take 5 readings and average the results.
5	RMT	Record CO ₂ readings in appropriate spaces of MS004-F2, Monthly Monitoring Form	MS004-F2, Monthly Monitoring Form	If there is greater than 10% points difference from previous reading, initiate appropriate maintenance actions.
6	RMT	Close valve on test port		
7	RMT	Disconnect hose in reverse order of connection		
8	RMT	Double check that biogas test port valve is closed prior to leaving area		
9	RMT	Transmit data to MLB operations	Fax, Electronic, etc	Enter into EnviroCert
10	QA	Perform Quality Control Check for format, integrity, etc.		
11	OP	Confirm reading within expected limits IAW manufacturer guidelines.		
12	OP	Store Data		
Farm: FH – Farm Hand; DP – Data Processor; FM – Farm Manager; AgCert: RMT – Regional Monitoring Technician, QA – Quality Assurance; OP – Operations, EN - Engineer				

Records Control

RECORD ID	RECORD LOCATION	RETENTION TIME	DISPOSITION
MS004-F2, Monthly Monitoring Form	Document Control Center	Duration of project + 2 years	Destroy

**Work Instruction for monitoring ID 3, Fraction of time Combustion Equipment Operates**

Summary

This ID monitors the time in which gas is combusted.

References

- UNFCCC approved monitoring methodology: AMS-III.D., Methane Recovery
- MS004-F2, O & M Monthly Monitoring Form
- P025, Control of Monitoring and Measuring Device (MMD)

Prerequisite(s)

Processes

- I036-9, Bio-security and Safety

Training of Monitoring Personnel

- Regional Maintenance Technicians and operations personnel shall be trained on data collection transfer processes.

Equipment, Materials and Tools

- Biogas Flow Meter

Calibration

- Prior to using a measuring device, ensure it is calibrated.

Process

Step	Operator	Activity	Documentation	Comments
1	RMT	Record reading in appropriate area of MS004-F2, Monthly Monitoring Form	MS004-F2, Monthly Monitoring Form	
2	RMT	Transmit data to MLB operations	Fax, Electronic, etc	Enter data into EnviroCert
3	QA	Perform Quality Control Check for format, integrity, etc.		
4	OP	Confirm reading within expected limits IAW manufacturer guidelines.		
5	OP	Store Data		
Farm: FH – Farm Hand; DP – Data Processor; FM – Farm Manager; AgCert: RMT – Regional Maintenance Technician; QA – Quality Assurance; OP – Operations, EN – Engineer				



Records Control

RECORD ID	RECORD LOCATION	RETENTION TIME	DISPOSITION
MS004-F2, Monthly Monitoring Form	Document Control Center	Duration of project + 2 years	Destroy

Work Instruction for monitoring ID 4, Flare Efficiency

Summary

This parameter guarantees the correct performance of digester and gas recovery.

References

- Approved monitoring methodology: AMS-III.D., Methane Recovery.
- P025, Control of Monitoring and Measuring Devices
- MS004-F2, O & M Monthly Monitoring Form

Prerequisite(s)

Processes

Efficiency is tested prior to installation and amount of methane consumed is calculated based on the efficiency rating. According to the methodology, the flare efficiency shall be calculated as fraction of time the gas is combusted in the flare multiplied by the efficiency of the flaring process.

The flaring combustion system is automated to ensure that all biogas that exits the digester and passes through the flare (and flow meter) is combusted. Pressure control devices within the gas handling system maintain proper biogas flow to the combustion system. A continuous ignition system ensures methane combustion whenever biogas is present at the flare. Two (2) sparking electrodes provide operational redundancy. If biogas is present in the flare, it is immediately ignited by the sparking system. If biogas is not present, the igniter sparks harmlessly. This continuous ignition system is powered by a robust solar module (solar-charged battery system) that operates independently from the power grid. The component parts are tested and verified functional on a periodic basis in accordance with manufacturer and other technical specifications and those results are examined by the verifying DOE.

Equipment, Materials and Tools

- None

Calibration

- Prior to using a measuring device, ensure it is calibrated.

Process

Step	Operator	Activity	Documentation	Comments
------	----------	----------	---------------	----------



Step	Operator	Activity	Documentation	Comments
Farm: FH – Farm Hand; DP – Data Processor; FM – Farm Manager; AgCert: RMT – Regional Monitoring Technician, QA – Quality Assurance; OP – Operations, EN - Engineer				

Records Control

RECORD ID	RECORD LOCATION	RETENTION TIME	DISPOSITION

EMISSION REDUCTION CALCULATIONS**Classification**

The methodology calls for the classification and categorization of the farm system to include animal type, population, AWMS in use/projected, climate, region, etc. This data is used to properly select lookup table parameters.

Calculating Methane (CH₄) Emissions

Step 1: Record biogas meter reading (ID1).

Step 2: Record the percentage of methane of the biogas (ID2).

Step 3: Multiply step 1 and step 2 and subtract the amount of biogas for the times biogas was produced but the flare was not working.

Step 4: Multiply step 3 by the flare efficiency.¹⁹

¹⁹ For the purposes of estimating ERs, the value of 99% was used based on EPA studies on flaring processes for the same type of enclosed flare used in this project:
<http://www.epa.gov/cmop/pdf/022red.pdf#search=%22EPA%20enclosed%20flare%20efficiency%22>



Annex 4

Control of Measuring & Monitoring Devices (MMD)

PURPOSE

The purpose of this document is to ensure that all MMD's used to demonstrate product conformity with specified requirements is identified, controlled and gauged at prescribed frequencies and that records for these activities are kept.

SCOPE

This document applies to all MMD's as well as software, used to verify product conformity with specified requirements. It applies to all individuals responsible for the selection, maintenance, and use of MMD's.

ASSOCIATED DOCUMENTS

MS004, O & M Manual
P005, Corrective and Preventative Action

DEFINITIONS

OM:	Operations and Maintenance
OPS:	Operations
QA:	Quality Assurance
RMT:	Regional Maintenance Technician
SUP:	MMD Supplier



PROCEDURE

	Responsibilities	Associated Documents
1 Identify the need for measuring and/or monitoring devices/software	OM, OPS, QA, SUP	A
↓		
2 Determine type of equipment based on required accuracy	OM, QA, SUP	A
↓		
3 Upon purchase and/or installation, initiate record for equipment.	OM, OPS, RMT, SUP	A
↓		
4 Establish frequency and calibration method or verification activity	OM, QA, SUP	A
↓		
5 Correct any “Out of Tolerance” conditions.	OM, RMT, SUP	A, B

NOTES

- BOX 1. OM, OPS, and QA, together with SUP shall identify MMD’s/Software that will be used to monitor equipment performance.
- BOX 2. MMD’s/Software will be selected/designed as best suited to ensure proper performance. Determination of MMD’s/Software required shall be based on the measurements to be taken and the accuracy required.
- BOX 3. Calibrated Devices will be labeled at a minimum with a unique identification number, status of calibration and date next calibration due. Records will be maintained that show the actual state of each piece of equipment, physical conditions of calibrating equipment and actual



readings obtained from calibration and/or verification. Records will be maintained in accordance with section 7.0 Record Control.

BOX 4. Off-the-shelf equipment will be calibrated in accordance with the SUP recommended calibration cycle.

Custom-gauged equipment calibration intervals shall be defined by OM & SUP. The calibration intervals can be adjusted based on the analysis of previous calibration results and at the discretion of OM & SUP.

Third Party Calibration Service will be managed as if activity was performed by company personnel. This will include requirement that all Qualifying Certifications and references to NIST Standards be submitted/maintained.

BOX 5. Devices found to be out of tolerance will be adjusted/repared. An investigation will be conducted to determine the effect that the out of tolerance condition may have had on the ability to verify conformance of product to customer requirements and to determine what action, if any, should be taken.

RECORD CONTROL

RECORD ID	FILE LOCATION	RETENTION TIME	DISPOSITION
Equipment calibration records	Site of use	1 year after equipment has been removed from service	Destroyed